

Honeywell

MAXON

VALUPAK®-II

Low Temperature Burners

TECHNICAL CATALOG



- **High turndown**
- **Available in 4 sizes**
- **Capacities 2 kW - 558 kW (HHV)**
- **Stable and clean combustion**
- **Suitable for UV scanner and flame rod**
- **Low gas pressure requirements**
- **Ease of installation and operation with low maintenance requirements**
- **All metal construction**
- **Multi voltage and frequency blower motors**
- **Better control on CO over the entire turndown of the burner**
- **Pilot connection availability**
- **Easily Switch between Natural Gas and Propane**

PRODUCT DESCRIPTION

The VALUPAK®-II is designed for process air heating applications.

A motorized gas control valve controls the heat output of the burner over the full operating range. The gas flows through the nozzle and then along the inside of the burner cone where combustion air is progressively and tangentially mixed with the gas. This results in a short, very stable flame and clean combustion.

Like many other Honeywell products, the standard VALUPAK-II burner can be customized into a package which could include a gear motor, burner controls, automatic shut-off valves, flame sensors and/or pressure switches.



32-00188-01

AVAILABLE VALUPAK®-II SIZES

Capacity and selection data in kW, 50 Hz operation									
Gross heating value = 10.9 kWh/m ³ (st), d = 0.6									
All figures are for balanced - 0 mbar - duct pressure [1]									
VALUPAK®-II size		60 [2]			150[2]		300[2]		600
Standard blower type		UHC 102	UHC 122	UMI 300	UMI 300	U/HC 122	UMI 300[5]	UMI 390	
Maximum heat release [3]	kW (HHV)	40	60	80	225	185	290	360	558
Minimum heat release	kW (HHV)	2	2	3	6	6	6	10	15
Turndown		20:1	30:1	27:1	38:1	31:1	48:1	36:1	37
Gas Q max.	m ³ (st)/h	3.7	5.5	7.3	21.8	17.9	28.1	34.8	54
Gas Q min.	m ³ (st)/h	0.18	0.18	0.28	0.6	0.6	0.6	1	1.5
Max. combustion air volume	m ³ (st)/h	48	64	98	251	206	323	401	622
Gas pressure at test connection at maximum heat release	mbar	5.4	9	18	14.6	9.8	5	7.7	10.2
Gas pressure at inlet burner at maximum heat release	mbar	6.7	11.5	24	20.8	14.2	10.8	15.2	16.2
Blower motor 3x220-420x50 Hz	kW	0.09			0.25	0.09	0.25	0.55	1.1
Weight	kg	n/a			24.2	20	29.7	31.5	47.6
Flame length [4]	m	up to 0.4 (after sleeve)			1	1	1.3	1.5	1.6

- [1] Air pressure switches should be selected to have a setpoint ranging from (2-10) mbar-, with exception of the VALUPAK®-II 60 burner with a capacity of 40 kW or 60 kW: setpoint ranging from (0.4 - 3) mbar
- [2] Single phase blower motor available.
- [3] Use of the standard round air inlet filter will cause a $\pm 15\%$ capacity reduction. UMI blowers are not suited for filters. Use of the standard VALUPAK®-II burner at 60 Hz will result in a higher max. capacity to which the gas pressures need to be adapted.
- [4] When firing in open air. Firing in a cross flow shortens flame.
- [5] As an alternative blower U/HC 142 (0.18 kW) can be used, performance are same as with UMI300 blower

Protection: IP 54

- 1) 1/2" NPT gas inlet
 2) 3/4" NPT gas inlet
 3) 1" NPT gas inlet
 4) 1" NPT gas inlet

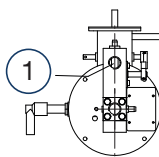

VALUPAK®-II 60

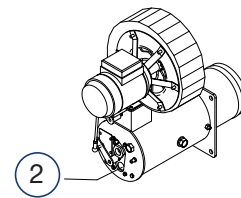

VALUPAK®-II 150

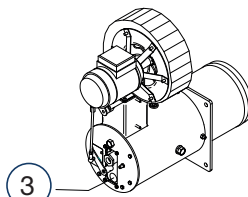

VALUPAK®-II 300

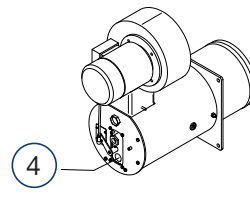

VALUPAK®-II 600

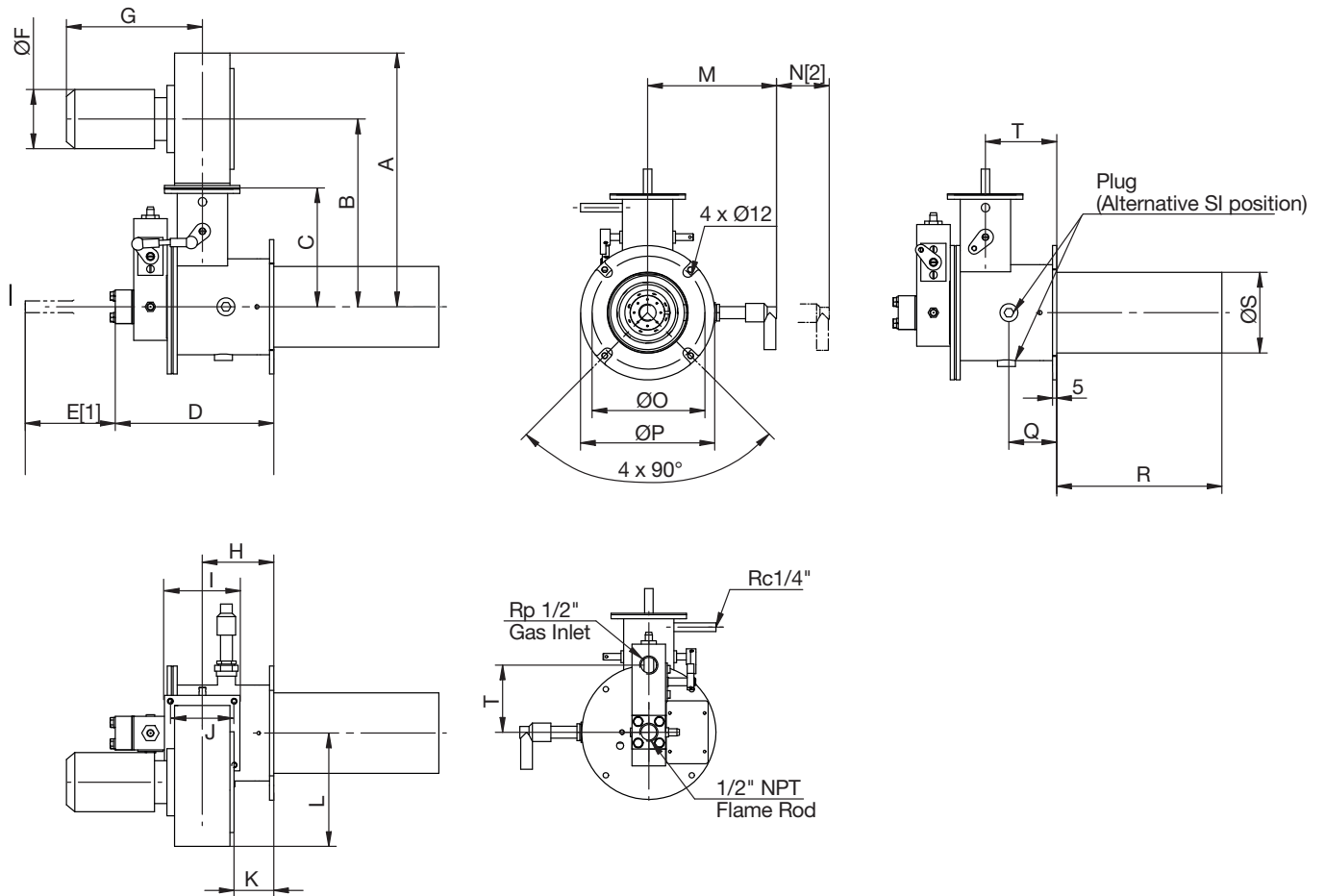
DIMENSIONS - VALUPAK®-II 60

VP-II 60	Dimensions in mm unless stated otherwise																		
Blower	A	B	C	D	E _[1]	ØF	G	H	I	J	K	L	M	N _[2]	ØO	ØP	Q	ØS	T
UHC 102	302	224		189	270	70,5	162				47	135							
UHC 122	442	331	142	189	270	112	208	85	90	76	42	179	154	150	135	160	57	96	85
UMI 300	539	389				120	247				41	248							

[1] min. free space required for flame rod removal.

[2] min. free space required for SI removal.

DIMENSIONS - VALUPAK®-II 150, 300 & 600

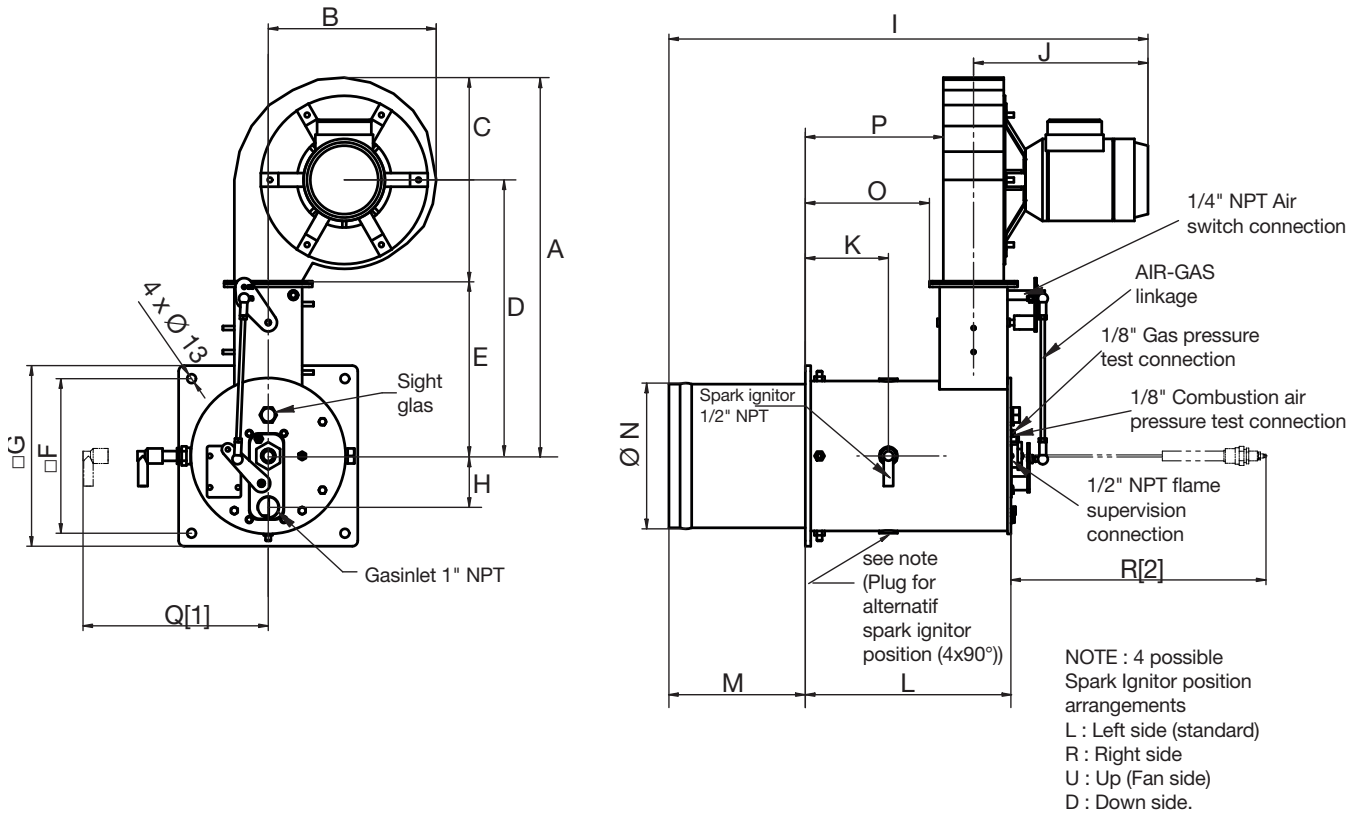

VALUPAK®-II		Dimensions in mm unless stated otherwise																
Burner size	A	B	C	D	E	F	G	H	I	J	K	L	M	ØN	O	P	Q[1]	R[2]
150	481	248	300	332	182	184	214	55	637	257	123	275	150	160	165	186	240	500
300	553	248	300	404	254	226	264	75	706 (UMI300) 733 (UMI390)	257 (UMI300) 284 (UMI390)	123	303	200	213	183	204	277	500
600	549	248	287	403	262	286	318	85	805	293	131	379	200	262	227	250	325	560

[1] Minimum free space required for Spark Ignitor removal.

[2] Minimum free space required for Flamerod removal.

Dimensions with alternatives for UMI blowers available on request.

APPLICATIONS

Specifically designed for applications where burners are used under balanced pressure conditions such as in textile machines, printing machines and many other types of dryers.

When firing with heat exchangers, the VALUPAK®-II design reduces the tendency for resonance.

Application examples VALUPAK®-II

Options

- round air filter
- single phase motor for sizes 60, 150 and 300
- long discharge sleeve 300 mm
- control motor
- flame rod or UV scanner
- Pilot connection



- 1) Cock
- 2) Housing
- 3) Male insert
- 4) Flame safeguard + Ignition transfo
- 5) Mounting bracket
- 6) Gasburner
- 7) Ignition terminal cap
- 8) Aptaptor set for control motor
- 9) Blower
- 10) Control motor
- 11) Flame rod
- 12) Double shut-off valve

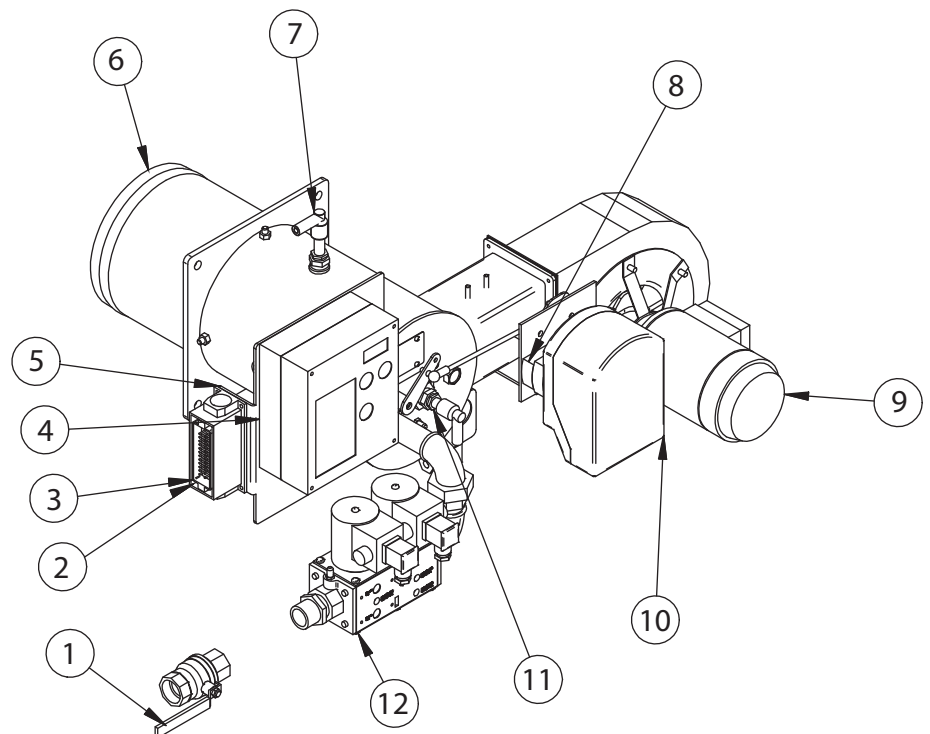

SPECIFICATIONS OF VALUPAK®-II BURNERS FOR 50 HZ OPERATION

Capacity data in kW									
Gross heating value = 10.9 kWh/m ³ (st), d = 0.6. All figures are for balanced - 0 mbar - duct pressure									
VALUPAK®-II size		60 ^[1]			150 ^[2]		300 ^[1]		600
Standard blower type		UHC 102	UHC 122	UMI 300	UMI 300	U/HC 122	UMI 300 ^[3]	UMI 390	
Maximum heat release ^[2]	kW(Hs)	40	60	80	225	185	290	360	558
Minimum heat release	kW(Hs)	2	2	3	6	6	6	10	15
Turndown		20:1	30:1	27:1	38:1	31:1	48:1	36:1	37:1
Gas Q max.	m ³ (st)/h	3.7	5.5	7.3	21.8	17.9	28.1	34.8	54
Gas Q min.	m ³ (st)/h	0.18	0.18	0.28	0.6	0.6	0.6	1	1.5
Max. combustion air volume	m ³ (st)/h	48	64	98	251	206	323	401	622
Excess air at maximum heat release	(n)	1.17	1.17	1.17	1.2	1.2	1.2	1.2	1.2
Gas pressure at test connection at maximum heat release	mbar	5.4	9	18	14.6	9.8	5	7.7	10.2
Air diff. pressure at test connection									
at maximum heat release	mbar	2	3.3	6.3	4.4	2.6	3.7	6.5	6.9
at minimum heat release	mbar	0.3	0.2	0.3	0.25	0.15	0.2	0.2	0.45
Blower motor 3x220-420x50 Hz	kW	0.09			0.25	0.09	0.25	0.55	1.1
Weight	kg	n/a			24.2	20	29.7	31.5	47.6

[1] Single phase blower motor available.

[2] Use of the standard round air inlet filter will cause a $\pm 15\%$ capacity reduction. UMI blowers are not suited for filters. Use of the standard VALUPAK®-II burner at 60 Hz will result in a higher max. capacity to which the gas pressures need to be adapted.

[3] As an alternative blower U/HC 142 (0.18 kW) can be used, performance are same as with UMI300 blower.

INSTALLATION AND OPERATING INSTRUCTIONS

Installation instructions

Instructions provided by the company or individual responsible for the manufacture and/or overall installation of a complete system incorporating MAXON burners take precedence over the installation and operating instructions provided by MAXON. If any of the instructions provided by MAXON are in conflict with local codes or regulations, please contact MAXON before initial start-up of equipment.



CAUTION

Read the combustion system manual carefully before initiating the start-up and adjustment procedure.

Verify that all of the equipment associated with and necessary to the safe operation of the burner system has been installed correctly, that all pre-commissioning checks have been carried out successfully and that all safety related aspects of the installation are properly addressed.

Do not discard packing material until loose items are accounted for. To prevent damage in transit spark ignitor and linkage (if any) are shipped “loose”.

Burner mounting

See sketch page 8. Burner may be mounted in any position suitable for automatic control motor and UV scanner.

Burner will typically be installed through an oven wall or insulated air duct. Cut opening at least 25 mm larger in diameter than discharge sleeve to allow for sleeve expansion.

Additional burner support may be required in conjunction with a stiffener plate to support burner package weight (20–25 kg). Four 13 mm diameter holes into panels flange accept 10 mm stud bolts welded to panels or stiffener.



CAUTION

seal welding of burner flange to stiffener plate at (A) may cause warpage of burner flange and require additional seal material to prevent leakage.

For push-through systems, area (A, see drawing page 8) should be sealed with additional gasketing or high temperature packing, to prevent back flow of high temperature air. Fill area (B, see drawing page 8) with no more than 50 mm of high temperature packing (too little will overheat mounting, too much will overheat sleeve).

For pull-through systems, spacers may be installed on stud bolts and area (B, see drawing page 8) left empty to permit cooling air past the sleeve.

Four lock screws permit centering mixing cone within burner body and sleeve. They should be drawn up hand-tight, then backed out 180° to allow for cone expansion.

They must be rechecked after start-up and loosened if necessary to prevent deformation of cone. See start-up instruction for details.

Tightening can lead to cone distortion and greatly reduced cone and discharge sleeve life.

Discharge sleeve must be flush with, or extended beyond interior wall.

A viewing port should be provided for flame observation in such a position that burner flame can be fully seen.



CAUTION

Installer must comply with all applicable codes and standards. Observe required space for parts removal.

Installation of flame scanner

Instead of a flame rod, a flame scanner can be applied to a VALUPAK®-II burner (with exception of VALUPAK®-II 60) without any modification.

- 1) Stiffener plate
- 2) Lock screw
- 3) Discharge sleeve
- 4) Viewing port
- 5) Additional burner support
- 6) Stud bolt
- 7) Air pressure switch (option)
- 8) Air filter (option)
- 9) Air supply
- 10) Fuel supply
- 11) Space required for spark ignitor removal
- 12) Oven wall
- 13) Control motor (option)
- 14) Space required for flame rod/scanner removal

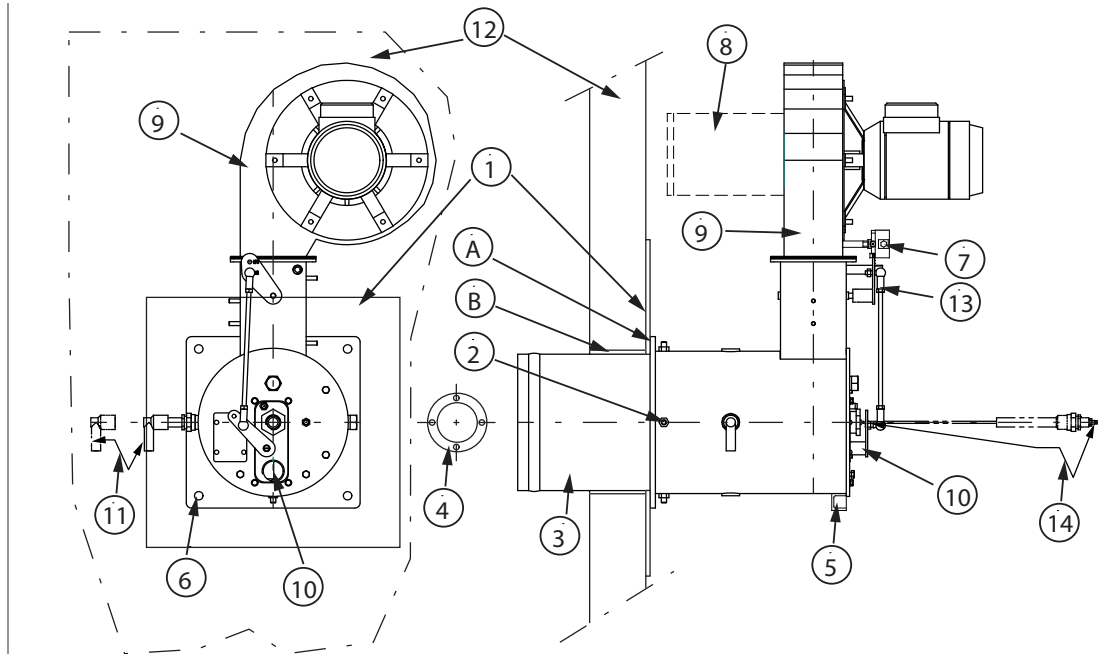

Flame rod or UV scanner arrangement with spark ignitor

Sizes VP-II 60 - VP-II 600

Spark ignitor

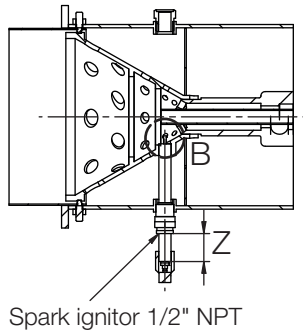

Spark ignitor 1/2" NPT

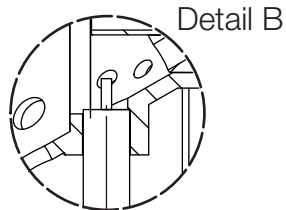

Flame rod arrangement

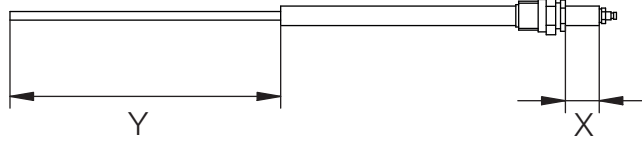

Dimensions in mm, unless stated otherwise

Model VALUPAK®-II	Spark ignitor	Flame rod	
	Z	X	Y
VP-II 60/UHC 102	44	35	65
VP-II 60/UHC 122		70	152
VP-II 60/UMI 300		70	152
VP-II 150	15	60	200
VP-II 300	33	25	200
VP-II 600	27	15	324

Spark ignitor arrangement for VALUPAK®-II

The spark ignitor can be mounted in 4 different positions on the burner housing : left (standard), right, top and bottom (if the air inlet is on top). Spark ignitor replacement : insert the spark ignitor through the collar into the burner. Insert the spark ignitor in the cone bushing until its ceramic touches the cone.

Flame rod arrangement for VALUPAK®-II

The flame rod is located at the back of the burner, through the scanner tube. It's important that the flame rod is mounted gastight! The recommended adjusting dimension shall be respected.

Operating instructions

The operating instructions below are provided only as a guideline and are not intended to replace those provided by the manufacturer of a complete system of which the VALUPAK®-II burner is only a part. Where applicable, instructions provided by the system's manufacturer shall take precedence.

Start

1. Make sure trip release shut-off valve and main gas cock are all closed.
2. Make sure the burner firing rate control handle is at predetermined low fire "LO" position.
3. Start all circulating and exhaust fans.
4. Energize system control panel (if applicable).
5. Start burner blower motor.
6. Open main gas cock.
7. Press start button.
8. Main gas valve will open (only if all safety circuits are complete).

Stop

1. Push STOP button and
2. Main gas valve should automatically close.
3. De-energize system control panel and burner blower motor.
4. Close main gas cock.

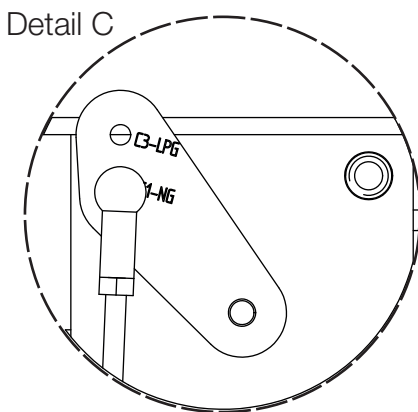
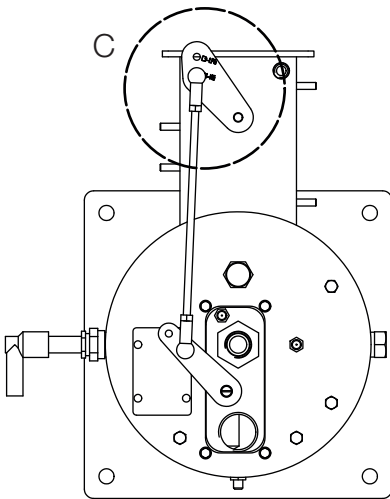

START-UP AND ADJUSTMENT INSTRUCTIONS FOR VALUPAK®-II BURNERS

Instructions provided by the company or individual responsible for the manufacture and/or overall installation of a complete system incorporating MAXON burners take precedence over the installation and operating instructions provided by MAXON. If any of the instructions provided by MAXON are in conflict with local codes or regulations, please contact MAXON before initial start-up of equipment.



CAUTION

Before initiating the following start-up and adjustment procedure, it is important that a check be made to verify that all of the equipment associated with and necessary to the safe operating of the VALUPAK®-II burner system has been installed and piped in accordance with the "General installation instructions". If the burner system is part of an oven or other heating unit which has been purchased as a complete pre-piped and pre-wired package, it may be assumed that these instructions have already been carried out by the individual or company responsible for the overall installation.

Initial adjustment and light-off should be undertaken only by trained and experienced personnel familiar with combustion systems, with control/safety circuitry and with knowledge of the overall installation.

To start-up a VALUPAK®-II burner for the first time

1. **Close main gas cock.** Check tightness of gas piping. Connect U-tube manometer to burner test connection on the burner gas nozzle inlet. Note burner type and required gas pressure (page 6).
2. **Establish correct blower direction of rotation of all fans.** See arrow on blower housings.
3. **Disconnect automatic control motor wiring to avoid unexpected motor travel.** Check that gas control valve is at low fire position (as supplied). For size 150, 300 and 600 control motor rotation is counter clockwise when looking towards controls linkage going from low to high fire. For the size 60 when looking to the linkage the air butterfly crank rotation is counter-clockwise. Since the control motor is located at the opposite side of the linkage its rotation is clockwise from low to high fire.
4. **When operating the burner with LPG instead of natural gas,** the linkage connection on the air valve crank needs to be changed. In order to do this, unscrew the nut (M6) at the back of the crank and relocate the linkage from the hole marked "C1 - NG" to the hole "C3 - LPG" by slightly rotating the crank and linkage. Screw the nut back in place. No further modification on the burner needs to be done. (See Detail C, to the left)
5. **Bleed air from the fuel supply line.** Remove the cover from the gas pressure regulator and establish that regulator is at low end of control range.

6. **Check the adjustments of the flame rod, spark ignitor and/or pilot** (See page 9 and the wiring).
7. **Start all machine air blowers.** Start burner with its start-stop switch. Motor of combustion air fan will be started shortly after, by means of the burner flame safeguard programming relay.
8. **Purge the combustion chamber,** purging any explosive vapors that may have accumulated prior to the start. The length of purge time required will usually be specified by insurance or approval agency having jurisdiction and depends on the total amount of fresh air and the volume of combustion space. A 5-fold refresh rate should be minimum. At the end of the purge time of the burner flame safeguard programming relay ignition is energized and the main gas valve will be energized shortly after.
9. **Because main gas cock** is closed the programmer will lock out requiring manual reset. Operation of programmer is correct.
10. **Check setting** of low and high gas pressure switches and combustion air pressure switch.
11. **Check burner control valve** at LO position.
12. **Slowly open main gas cock.** Reset burner relay and start burner.
13. After the burner flame safeguard programmer relay prepurge time ignition is energized and main gas valve opened. Flame should be established within safety time of programmer. If again flame failure, air could still be in gas supply line just before burner. Reset programmer and restart until low fire flame is established. Check gas supply pressure with information on page 2 and correct with adjusting screw of gas pressure regulator. In the case of LPG firing, multiply the referenced natural gas pressures by 0.4 to arrive at optimal LPG pressures. Observe flame through observation port at rear of burner.
14. **Slowly bring burner to high fire position** and avoid maximum temperature of dryer. Check and correct gas pressure on burner test connection and adjust to value given on page 2. Close cover on pressure regulator and adjust all pressure switches.
High gas pressure switch at low fire.
Low gas pressure switch at high fire.
Air pressure switch at high fire by closing of air inlet until flame color start to change. Burner should trip by air pressure switch.
15. **Reconnect control motor wiring,** start burner and change several times between low and high fire position by changing temperature controller settings.
16. **Check all other safety devices** such as pressure switches, high temperature limits etc. and adjust these devices to their correct values.

For More Information

The Honeywell Thermal Solutions family of products includes Honeywell Combustion Safety, Eclipse, Exothermics, Hauck, Kromschröder and Maxon. To learn more about our products, visit ThermalSolutions.honeywell.com or contact your Honeywell Sales Engineer.

Honeywell MAXON branded products

201 E 18th Street
Muncie, IN 47302
USA

www.maxoncorp.com

Honeywell Process Solutions

Honeywell Thermal Solutions (HTS)
1250 West Sam Houston Parkway
South Houston, TX 77042
ThermalSolutions.honeywell

® U.S. Registered Trademark
© 2018 Honeywell International Inc.
32-00188-01 M.S. Rev. 06-18
Printed in United States

