

Specifications of M-PAKT® Burners

Typical burner data						
Fuel: natural gas at 60°F with 1000 Btu/ft ³ (st) HHV - sg = 0.6 (1)						
Combustion air: 60°F - 21% O ₂ - 50% humidity - sg = 1.0 (1)						
Stated pressures are indicative. Actual pressures are a function of air humidity, altitude, type of fuel and gas quality						
Packaged Burners						
Size		0.4M	0.9M	1.5M	2.5M	3.5M
Maximum Capacity HHV (4)	MBtu/h	0.41	0.9	1.6	2.5	3.5
Minimum Capacity HHV		0.07	0.128	0.2	0.37	0.5
Turndown	N/A	5.9:1	7:1	8.5:1	7:1	7.4:1
Pilot Capacity	scfh	20-80	20-80	20-80	20-80	20-80
Natural Gas Pressure (3) (7)	" wc	4.1	10.4	8.6	10.3	14.4
Inlet Gas Pressure (5)	" wc	22.5	26.9	23.9	39.6	37
Inlet Gas Pressure (6)	"wc	8	25.5	19	37	33
Combustion Air Pressure at Test Port	" wc	8.8	8.8	9.3	10.4	10.3
Combustion Air Flow	scfm	116	225	453	708	992
Fan Horsepower	hp	1.5	2	2	3	3
Burner Sound Levels (2)	dB(A)	86.1	86.3	87.2	89.3	89.5
With Silencer		82.0	82.2	84.0	82.0	82.0

(1) sg (specific gravity) = relative density to air (density air = 0.0763 lb/ft³ (st))

(2) Sound pressure level, Lp, measured at 39 inches from the burner

(3) Gas pressure measured differentially at burner gas pressure test connection.

(4) Capacity displayed assumes blower operation on 60Hz electrical supply. Gross output will be reduced by 17% if operated on 50Hz. Fuel and air pressures should be reduced by 30% while motorpower will reduce 40% with 50Hz operation.

(5) Gas pressure required reflects gas control method (A)

(6) Gas pressure required reflects gas control method (L or S)

(7) Gas pressure required same for inlet pressure with gas control method (D)

Contact MAXON for operating pressures for burners produced prior to 5/1/07.

Typical burner data							
Fuel: natural gas at 60°F with 1000 Btu/ft ³ (st) HHV - sg = 0.6 (1)							
Combustion air: 60°F - 21% O ₂ - 50% humidity - sg = 1.0 (1)							
Stated pressures are indicative. Actual pressures are a function of air humidity, altitude, type of fuel and gas quality							
External Blower Burners							
Size	Units	EB2	EB3	EB4	EB5	EB6	EB7
Maximum Capacity HHV (1)	MBtu/h	0.8	1.7	2.7	4.5	5.8	8.4
Minimum Capacity HHV		0.07	0.128	0.2	0.37	0.5	0.9
Turndown	N/A	11.4:1	13.3:1	13.5:1	12.2:1	11.6:1	9.1:1
Pilot Capacity	scfh	20-80	20-80	20-80	20-80	20-80	20-80
Natural Gas Pressure (2) (5)	" wc	12.1	37.2	24	32.6	37	60
Inlet Gas Pressure (3)	" wc	38.8	58.8	54.9	75.9	66.7	90.6
Inlet Gas Pressure (4)	" wc	14.8	48.5	34.8	63	45.8	78
Combustion Air Pressure at Test Port	" wc	29.4	29.7	28	32.9	27.5	27.2
Combustion Air Flow	scfm	227	482	765	1275	1643	2380

(1) sg (specific gravity) = relative density to air (density air = 0.0763 lb/ft³ (st))

(2) Gas pressure measured differentially at burner gas pressure test connection.

(3) Gas pressure required reflects gas control method (A)

(4) Gas pressure required reflects gas control method (L or S)

(5) Gas pressure required same for inlet pressure with gas control method (E)

Contact MAXON for operating pressures for burners produced prior to 5/1/07.

Materials of construction

The M-PAKT Ultra Low NOx burner is constructed from durable, industrial steel and stainless steel components. Optional materials are available for higher temperature ratings.

Burner Part	Material
Housing	1010 steel
Gas nozzle	304 stainless steel (1.4301)
Cone	309 or 330 stainless steel (1.4828 or 1.4333)
Discharge sleeve	309 or 330 stainless steel (1.4828 or 1.4333)
Impeller	Aluminum
Fan case	Steel

Selection criteria

Models

M-PAKT® Ultra Low NOx Burners are available as packaged burners with integral blower and fuel/air ratio control valves.

M-PAKT® may also be ordered as an EB model for use with a remote blower. EB M-PAKT® burners also include required fuel/air ratio control valves.

Application details

M-PAKT® Ultra Low NOx burner is suitable for use in industrial air heating, drying, baking and curing applications. The burner produces extremely low levels of NOx and CO for air quality compliance and end product sensitivities.

Process temperature

The M-PAKT® may be used in applications up to 1400°F with optional high temperature materials of construction. Consult page 1-1.7-5 for guidance on selecting proper burner configurations.

Process flows and oxygen content

M-PAKT® burners may be applied in inert process streams as the burner supplies all the required air for combustion and the flame is fully contained in its discharge sleeve.

Process flows up to 2500 ft/m are allowed perpendicular to the discharge sleeve although this will affect emissions performance. For best emissions performance, limit the flow velocity at the burner's discharge to < 1000 ft/m. Protection plates or secondary sleeves are acceptable to limit the cross velocity.

Process back pressure

Packaged burner models with integral fan may be applied to applications with pressures between -4.0" wc and +2.0" wc. Specifications for EB M-PAKT® burners with 1 psi differential air pressure are listed on page 1-1.7-5. EB models may be used for extended capacities or for higher application pressures up to 5 psi. Consult MAXON for assistance with applications > 2 psi.

Piloting and ignition

Ignition of M-PAKT® burners should be restricted to the pilot. While direct ignition may be possible, it is not recommended.

The M-PAKT® burner is provided with an independent pilot burner. The pilot should only be operated as interrupted or intermittent. Standing pilots are not permitted as the flame scanner will not distinguish between the pilot and main flame.

In low oxygen or high moisture applications, an air feed for the pilot may be used. Consult pages 1-1.7-8 to 1-1.7-11 for location and size of pilot air connections. Pilot air is not required in most applications.



Ratio control

For applications with stable combustion chamber pressures and cross velocities < 1000 ft/min , the M-PAKT® is offered with a mechanically linked air and fuel valve. The fuel valve is characterizable to allow optimal tuning of the burner's emissions for a wide variety of differential pressure conditions. The mechanical version of the burner is most useful for very stable applications or for applications where optimal emissions are not required.

For greater assurance of optimal emissions or for less stable application pressures, MAXON suggests the use of parallel positioning actuator systems. MAXON's SMARTLINK® MRV provides high resolution control of the air and fuel valve for absolute control of air fuel ratio. The M-PAKT® Burner may be configured for a variety of available parallel positioning systems ordered separately. The external control option allows the M-PAKT® burner to be used with an external air/fuel ratio control system such as SMARTFIRE™.

Unlike inferior pressure regulators, high resolution parallel positioning provides absolute control even during transient conditions. This type of absolute control has proven to optimize efficiency while minimizing emissions of industrial burners.

M-PAKT® is not recommended for use with hi/lo or on/off control schemes. Main fuel valves used with M-PAKT® Burners should not exceed 6 second opening time.

Combustion air control and piping

Do not rotate combustion air blowers on packaged M-PAKT® burners. EB M-PAKT® burners require combustion air to enter the burner parallel to the burner's long axis.

Fuels

M-PAKT® burners provide low NOx performance on natural gas and propane only. Other clean fuel gases may be used in the burner, but performance and emissions may change.

Expected emissions

In typical applications with specified excess air, the M-PAKT® Ultra Low NOx burner will produce only 5% to 10% of the NOx of conventional burners. CO is controlled to extremely low levels but varies according to the specific application parameters of each installation.

Flame development

The flame of the M-PAKT® is entirely contained within the discharge sleeve of the burner making the the effective flame length zero. Avoid locating the discharge of the burner close to walls, equipment or product as the exiting gases may be 2800°F or higher.

Discharge Sleeve Selection

A variety of discharge sleeve options for the M-PAKT® burner provide outstanding durability for a wide range of heating applications. Choose the appropriate discharge sleeve option based upon application temperature, and desired excess air levels.

Desired Excess Air Adjustment	Application Temperature	
	< 1000°F	1000°F - 1400°F
55 - 70%	Standard 310 SS (1.4841)	Optional 330 SS (1.4333)
40 - 55%	Optional 330 SS (1.4333)	Not recommended

Dimensions

0.4M & 0.9M Packaged Burners

- 1) 1/8" NPT combustion air pressure test port
- 2) 1/2" NPT pilot air inlet (if required)
- 3) Observation port
- 4) Gas pressure test port
- 5) 1/4" NPT pilot gas inlet
- 6) Air pressure switch connection
- 7) Low fire switch
- 8) High fire switch
- 9) Chamber pressure test port
- 10) Spark ignitor
- 11) Flame scanner connection 1" NPT-F
- 12) Gas inlet
0.4M - 1/2" NPT (F)
0.9M - 3/4" NPT (F)

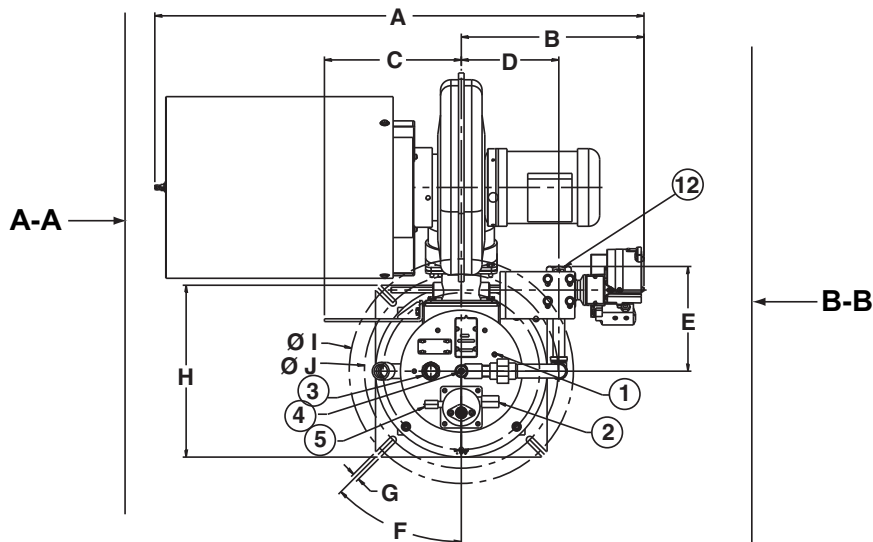

VIEW A-A

VIEW B-B

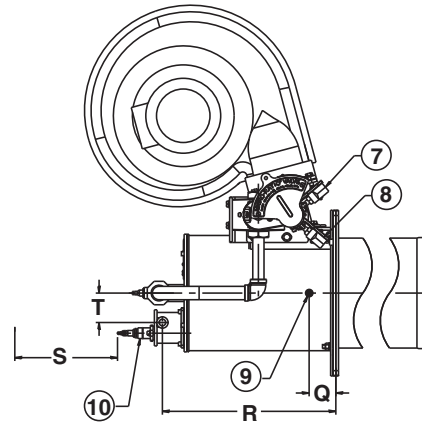
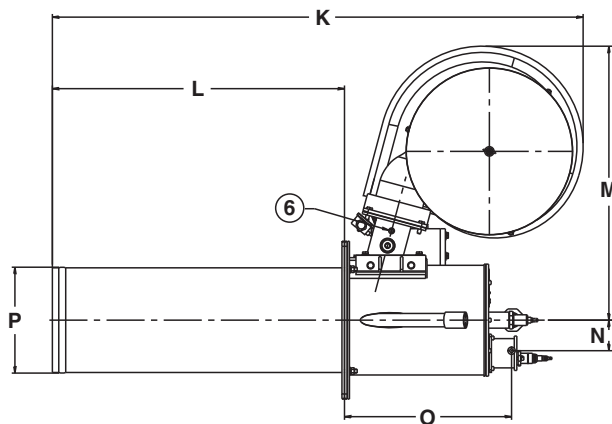

Dimensions in inches unless stated otherwise									
A	B	C	D	E	F	G slot	H square	I Ø	J Ø
44.19	16.5	12.37	8.81	9.44	45°	.62	15.5	20.25	17.5

Dimensions in inches unless stated otherwise									
K	L	M	N	O	P Ø	Q	R	S	T
52.2	28.75	26.9	3.0	16.44	10.4	2.5	16.21	28.0	2.75



WWW.MAXONCORP.COM

COMBUSTION SYSTEMS FOR INDUSTRY

Maxon reserves the right to alter specifications and data without prior notice.

© 2005 Copyright Maxon Corporation All rights reserved

EB2 and EB3 (External Blower) Burners

- 1) 1/8" NPT combustion air pressure test port
- 2) 1/2" NPT pilot air inlet (if required)
- 3) 1/4" NPT pilot gas inlet
- 4) Gas pressure test port
- 5) Observation port
- 6) Air pressure switch connection
- 7) Spark ignitor
- 8) 1" NPT-F flame scanner connection
- 9) Chamber pressure test port
- 10) Low fire switch
- 11) High fire switch
- 12) Gas inlet
EB2 - 1/2" NPT (F)
EB3 - 3/4" NPT (F)

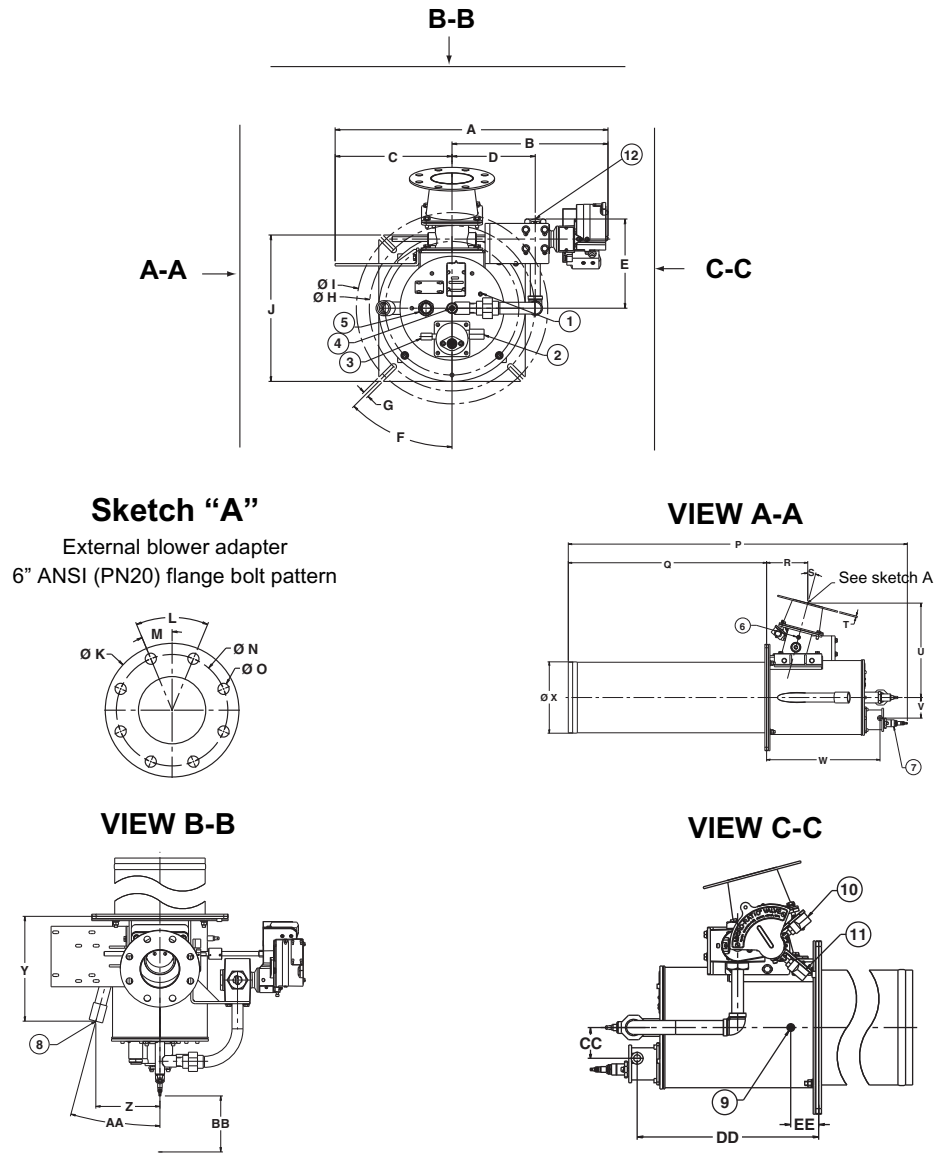

Dimensions in inches unless stated otherwise															
A	B	C	D	E	F	G slot	H Ø	I Ø	J	K Ø	L	M	N Ø	O Ø	P
28.87	16.5	12.37	8.81	9.44	45°	.62	17.5	20.25	15.5	9.0	45°	22.5°	7.5	.75	49.2

Dimensions in inches unless otherwise stated															
Q	R	S	T	U	V	W	X Ø	Y	Z	AA	BB	CC	DD	EE	
28.75	6.0	15°	.18	13.75	3.0	16.44	10.4	11.91	7.28	15°	28.0	2.75	16.21	2.5	

1.5M, 2.5M and 3.5M Packaged Burners

- 1) Chamber pressure test port
- 2) Air pressure switch connection
- 3) Gas pressure test port
- 4) Observation port
- 5) Combustion air pressure test port
- 6) 1/4" NPT pilot gas inlet
- 7) 1" NPT-F flame scanner connection
- 8) 1/2" NPT pilot air inlet (if required)
- 9) Spark ignitor
- 10) Gas inlet
1.5M - 1" NPT (F)
2.5M - 1-1/4" NPT (F)
3.5M - 1-1/2" NPT (F)

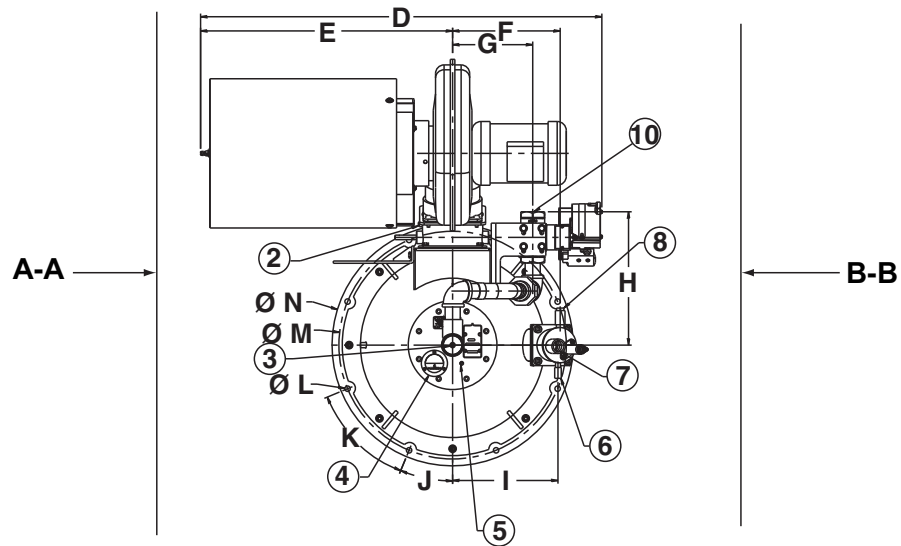

VIEW A-A

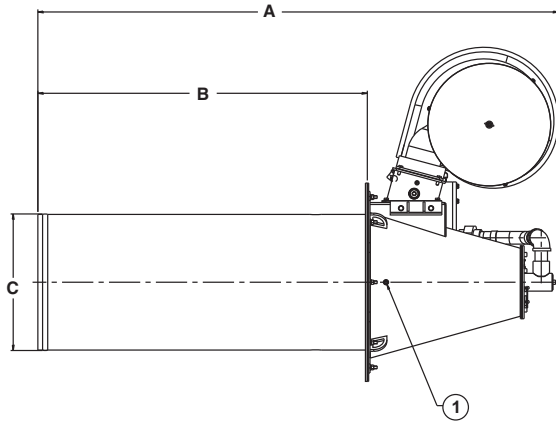

VIEW B-B

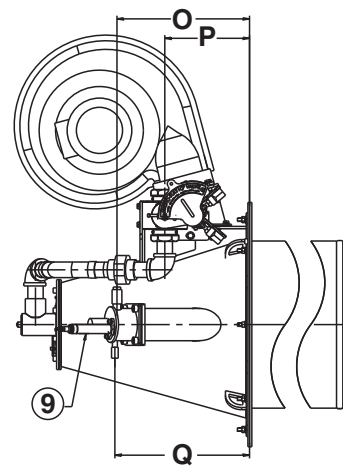

Dimensions in inches unless stated otherwise

A	B	C Ø	D	E	F	G	H	I	J	K	L Ø	M Ø	N Ø	O	P	Q
69.37	44.0	18.24	44.12	27.71	11.83	8.81	14.64	11.59	22.5°	45°	.59	25.0	26.5	14.35	9.17	14.58



EB4, EB5, EB6 & EB7 (External Blower) Burners

- 1) Air pressure switch connection
- 2) Chamber pressure test port
- 3) Gas pressure test port
- 4) Observation port
- 5) Combustion air pressure test port
- 6) 1/4" NPT pilot gas inlet
- 7) 1" NPT-F flame scanner connection
- 8) 1/2" NPT pilot air inlet (if required)
- 9) Spark ignitor
- 10) Gas inlet
EB4 - 1" NPT (F)
EB5 - 1-1/4" NPT (F)
EB6 - 1-1/2" NPT (F)

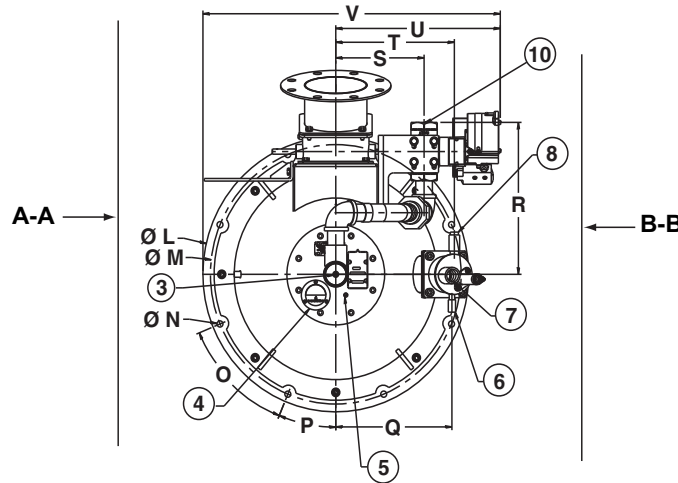

VIEW A-A

Sketch A
6" ANSI (PN20) flange bolt pattern

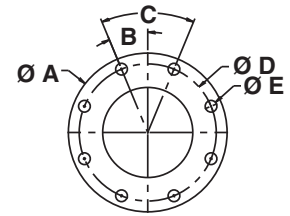

VIEW B-B

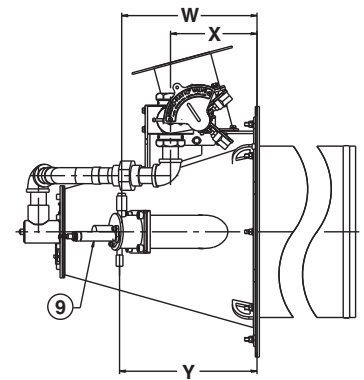
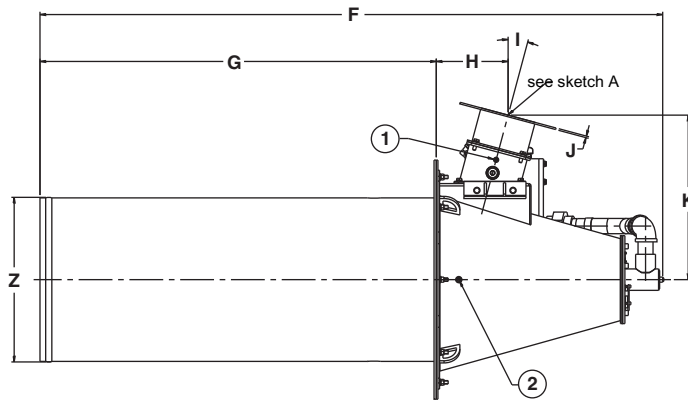

Dimensions in inches unless stated otherwise													
Burner Size	A Ø	B	C	D Ø	E Ø	F	G	H	I	J	K	L Ø	M Ø
EB4, EB5, & EB6	11.0	22.5°	45°	9.5	0.81	69.0	44.0	7.95	15°	0.18	18.23	26.5	25.0
EB7	11.0	22.5°	45°	9.5	0.81	69.0	44.0	7.95	15°	0.18	18.23	26.5	25.0

Dimensions in inches unless stated otherwise													
Burner Size	N Ø	O	P	Q	R	S	T	U	V	W	X	Y	Z
EB4, EB5, & EB6	.59	45°	22.5°	11.59	14.64	8.81	11.83	16.41	29.66	14.35	9.17	14.58	18.24
EB7	.59	45°	22.5°	11.59	14.64	8.81	11.83	20.0	33.0	14.35	9.17	14.58	20.24

Intelligent Model Numbers

A coded model number is provided on the nameplate of all M-PAKT® Burners to provide an instantaneous method to identify the configuration of the product. This model number ensures accuracy in identifying your product, ordering replacement parts or communicating capabilities.

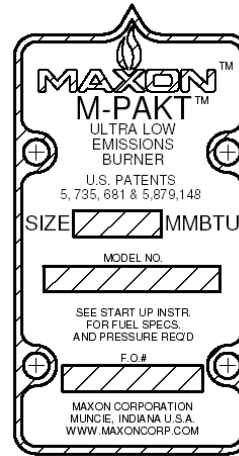

Configured Item Number

