

# Maxon Burner Nozzles

## STICKTITE™ & PILOTPAK™ Flame Retention Nozzles *for open-port firing*



Provides positive flame retention and stable clean burning, while directing the torch-shaped flame onto or through open ports to your heat processes. (Photo: "SP" PILOTPAK™ Nozzle with flame rod)

## Series "SN" Sealed Nozzles *with refractory tunnel block for sealed-port firing*

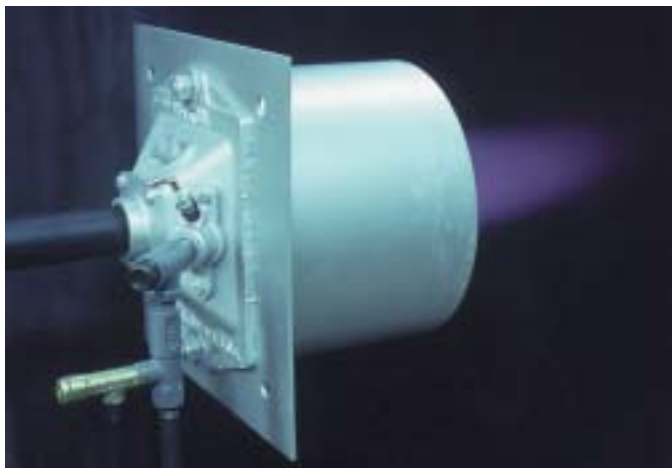

Improve higher temperature operating efficiency and atmosphere control by mounting the Sealed Nozzle assembly into your oven or furnace wall, effectively sealing out any secondary air introduction. (Photo: Series "SNF" Sealed Nozzle with pilot and seal & support housing)

Air/gas premixing equipment used to provide thorough blending of air/gas mixture to Maxon Burner Nozzles



**PREMIX® Blower Mixers**  
*(see catalog bulletin 3100)*



**MULTI-RATIO® Mixers**  
*(see catalog bulletin 3200)*



**Series "HG" Mixing Tubes**  
*(see catalog bulletin 3200)*



**Series "LG" Mixing Tubes**  
*(see catalog bulletin 3200)*



**VENTITE™ Inspirator Mixers**  
*(see catalog bulletin 3300)*



# Maxon Burner Nozzles

## Principle of Operation

**STICKTITE™ and PILOTPAK™ Nozzles** are designed for direct-fired air heating and/or open-port firing into a furnace, duct, or immersion tube. The single torch-like flame creates a venturi effect that pulls secondary air in around the burner nozzle and provides necessary cooling of the cast metal nozzle.

The burner nozzle is threaded onto the feed manifold from your air/fuel premixing device. This premixture is directed out through the nozzle's main port. A small portion of the premixture is channeled out through the smaller ignitor ports that surround the large main port. The gas/air mixture is ignited by a spark ignitor or separate pilot assembly.

The eddy currents created on the face of the nozzle provide positive flame retention of the torch flame emitted out of the main port. The flames from the tiny ignitor ports are protected from outside air turbulences and surround the base of main flame to continually ignite the premixture being forced out of the nozzle by the mixture pressure from your mixing device.

**Series "SN" Sealed Nozzles** are tunnel-type, refractory block, closed-port burners for firing of air/gas premixtures without secondary air. They are designed to be installed into refractory, thin-wall, or soft-wall combustion chambers and fed by almost any air/gas premixing system.

The air/gas mixture manifold from your premixing system is threaded into the Series "SN" Sealed Nozzle assembly. This premixture is directed out through the nozzle body's main port into the stepped-tunnels of the refractory burner block.

A pilot port tunnel and a flame supervision port (not shown in sketch below) intersect the main tunnel directly in front of the nozzle body's main port. At this three-way tunnel intersection, the flame safeguard (flame rod or UV scanner) monitors the pilot flame and/or main burner flame.

Once the air/gas premixture is ignited by a separate mounted pilot and spark ignitor, the flame front progressively steps out through the burner block's tunnels. The "hot" refractory and the eddy-currents created at each one of the steps within the tunnel serve to provide positive flame retention of the burner flame at all firing rates.

## Typical STICKTITE™ Nozzle Construction

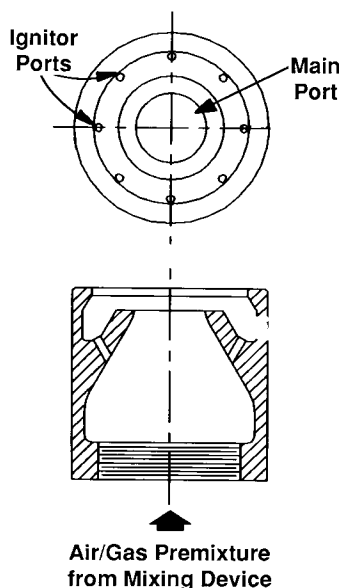

## Typical Series "SN" Sealed Nozzle Construction

