

Design Guidelines

Applications using oxygen-fuel burner technology can vary greatly. Maxon provides the following general guidelines for burner installation and operation. Furnace designers will provide design specifics for individual furnaces.

NOTE: Premium-quality materials have been used in the OXY-THERM® Burner, but metal components can be destroyed by high furnace temperatures if the burner is misused or left unprotected from cooling flows. Because most oxygen-fuel burner applications operate at very high temperatures, these guidelines focus on enhancing burner performance and longevity.

Operation Guidelines

1. If the burner will not be fired for an extended period, then the gas or oil insert should be withdrawn from the housing. The service nut should be installed in its place, and cooling air/oxygen flow established. **Minimum recommended cooling air/oxygen flows are 5 SCFM (8.5 Nm³/hr) for Series 600 OXY-THERM® Burners and 15 SCFM (25.5 Nm³/hr) for Series 900 OXY-THERM® Burners.** This cooling flow will extend component life and retard the collection of particulate material inside the burner block opening. As an alternative to cooling flow, the burner housing may be removed, if desired, leaving the block/frame assembly mounted to the furnace wall.
2. On oil-fired burners, reduced pressure atomizing oxygen/air/steam should be maintained when the burner is not firing. Continuous atomizing flow cools the nozzle and prevents oil from contacting oxygen-clean components. Atomizing pressure of 10 psig is sufficient for oxygen/air, 50 psig for steam.
3. Any time atomizing flow is shut off, oil inserts should be removed and recleaned to prevent fuel oil residue and oxygen from coming into contact inside the oil insert assembly.
4. To provide cooling flow to the burner housing, Maxon recommends installing a 3-way ball valve immediately upstream from the combustion oxygen connection on the burner (see diagram at right). Connect cooling source and combustion oxygen source to the valve.

The cooling source should not be compressed air, since compressed air may contain oils which contaminate oxygen-clean components. The valve should offer 180° operation, with shut-off at 90°. **Every component that comes in contact with oxygen must be cleaned for oxygen service.**

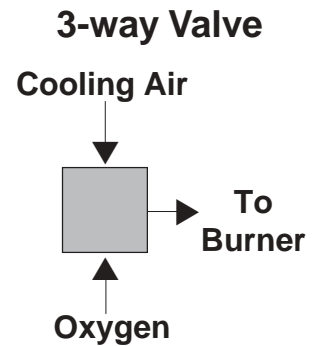

5. Quick-connect devices for the combustion oxygen, atomizing oxygen/air/steam and fuel will facilitate hook-up and installation, especially when switching from fuel gas to fuel oil. Quick-connect devices also limit the amount of time that burner components are exposed to furnace temperatures without cooling flow. This is helpful during hot conversions or when replacing existing burners.
6. Burner and piping should be supported as shown in the installation instructions. Unsupported piping puts stresses on the block/frame assembly resulting in block failures. Flexible connections are recommended in all piping. Adding flexible connections at appropriate locations in the oxygen or gas manifolding can prevent damage to the burners from piping stresses or uneven thermal expansion.
7. The AZS block is available for most fuel gas-fired applications. However, it is the responsibility of the user to assure that the AZS material is compatible with the user's process.
8. The Zirconia block is required for all fuel oil-fired applications, even if fuel oil will be used only as a back-up fuel. The Zirconia block may also be used for gas firing if the user has concerns about the compatibility of the AZS block with the process.

Design Guidelines (continued)

9. For oil-fired OXY-THERM® Burners, all liquids and atomizing oxygen/air/steam should be filtered. A 100-mesh duplex fuel oil filter is recommended.
10. For proper atomization, fuel oil should be supplied to the burner inlet at a viscosity of 100 SSU (20 centistokes) or less. A typical #6 fuel oil would normally be heated to approximately 220°F (105°C) to obtain proper viscosity.
11. All OXY-THERM® Burners should be specified to normally operate near design capacity.

- Maximum flame length occurs at maximum capacity. The OXY-THERM® threaded gas nozzle can be changed easily if more capacity is required in the future. Oil burners that are oversized will have dramatically shorter flame patterns.
12. Observation ports which provide a view of the flame will simplify burner start-up and adjustment.
 13. Burner block can be recessed into the inner furnace wall by as much as 3 inches.

Capacity / Selection Data

All Maxon gas OXY-THERM® Burners are custom drilled to meet your specific application requirements. This helps assure that you get the best possible burner to meet your specific job requirements.

NOTE: A calibrated flow meter in the gas and the oxygen line is recommended for establishing accurate volumetric flow rates.

Maxon oil OXY-THERM® Burners are available in two block sizes and six oil insert sizes (see chart below).

On the Gas OXY-THERM® chart, maximum capacities shown are a range of heat releases. Your specified maximum capacity dictates the individualized fuel drilling used in the manufacture of the burner's gas insert.

Gas OXY-THERM® Burner	Series 600	Series 900
Maximum capacity range in 1000's Btu/hr	200 to 2,000	1250 to 11,000
Turndown	1/5 of maximum capacity	
Required pressures to burner inlet for maximum capacities [1]	Oxygen	see curves on page 4605
	Natural gas	0.5 - 8 psig [1]
	Propane	1 - 20 psig [1]
Typical oxygen to fuel volumetric ratios [2]	To natural gas	2.05 to 1
	To propane	5.1 to 1
Approximate flame geometry	Length	1.0 - 1.5 ft per MMBtu/hr

[1] NOTE: Gas OXY-THERM® Burners are custom sized to meet your application and utility requirements. Please contact Maxon for specific details.

[2] Exact calorific values should be checked and oxygen/fuel ratio adjusted accordingly.

Oil OXY-THERM® Burners	Series	Series 900					
	Size	70	100	150	200	300	400
Maximum output (MMBtu/hr)		3.1	4.4	7.5	10.0	14.9	19.9
Maximum fuel flow (gallons/hour) (liters/hr)		21 (80)	30 (115)	52 (195)	69 (260)	103 (390)	137 (520)
Minimum fuel flow (gallons/hour) (liters/hr)		4.2 (16)	6 (23)	10 (39)	15 (57)	26 (98)	34 (130)
Turndown		5:1	5:1	5:1	4.6:1	4:1	4:1
Atomizing oxygen/air flow (scfh) at 50 psig		See curves on page 4608					
Oxygen pressure to burner inlet ("wc)		See curves on page 4605-4607					
Fuel pressure to burner inlet (psig) at maximum		See curves on page 4608					
Approximate flame length (feet) at maximum		5	9	10	14	18	20

NOTE: In the Imperial System, "MM" refers to 10⁶.

Capacity / Selection Data

Gas OXY-THERM® Burners Combustion Oxygen Pressure Curves

Series 600

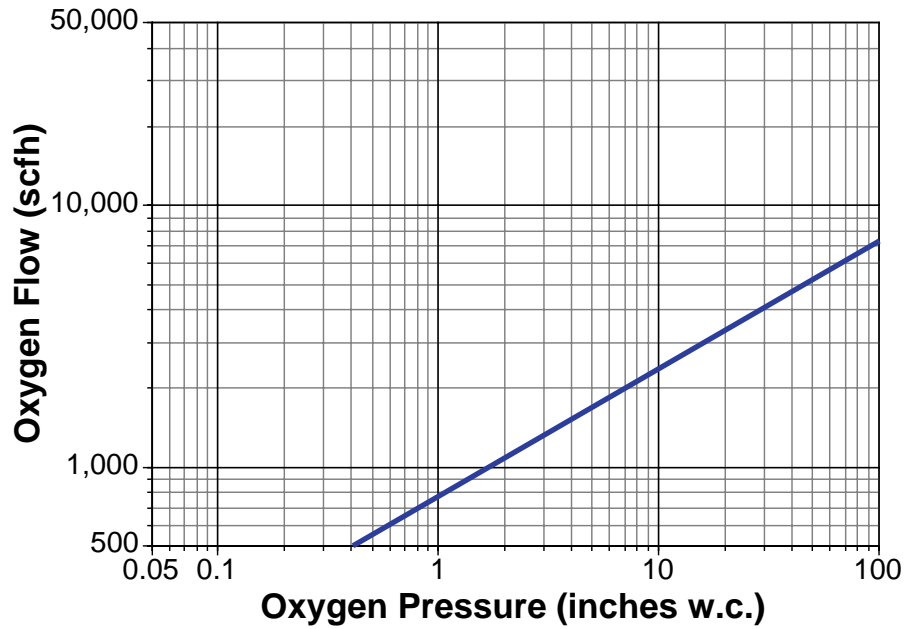

Series 900

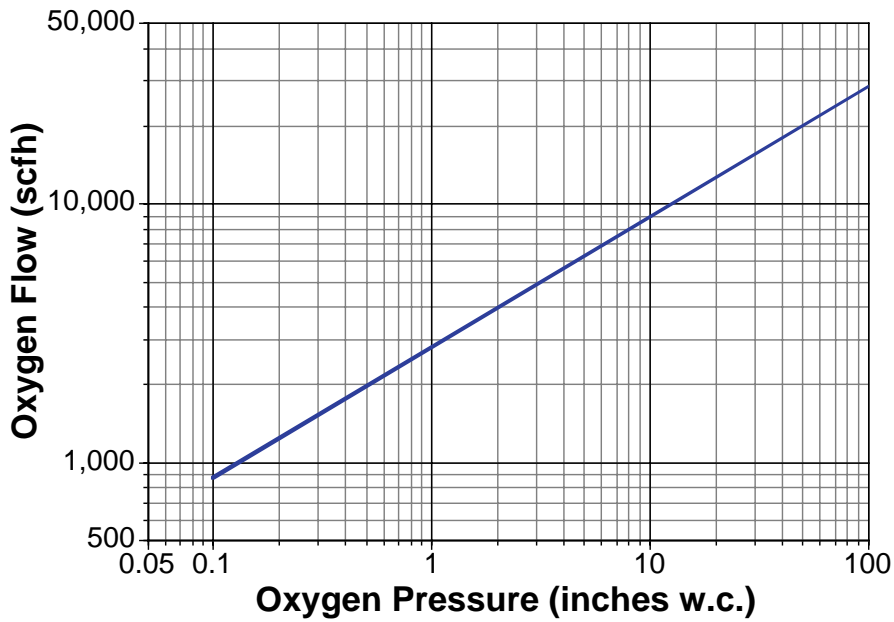

Capacity / Selection Data

Oil OXY-THERM® Burners Combustion Oxygen Pressure Curves

Series 600 (70 lph)

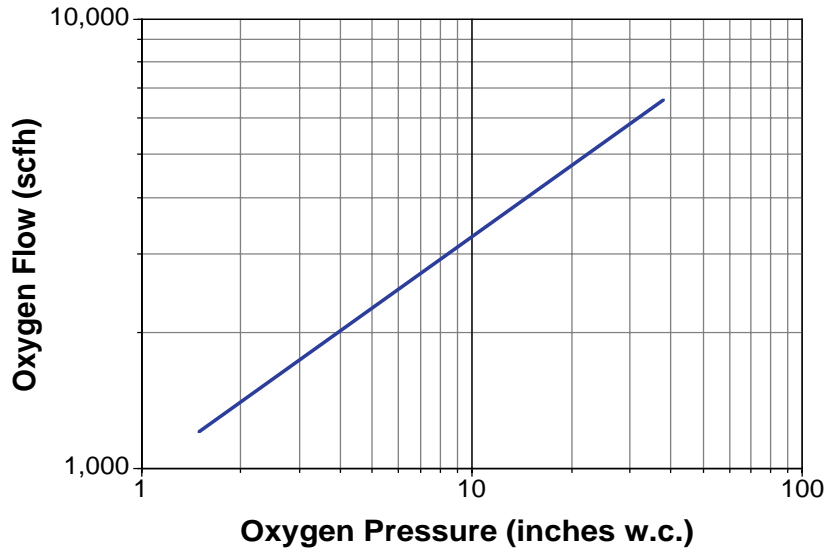

$$\Delta P_2 = \Delta P_1 \left(\frac{Q_2}{Q_1} \right)^2$$

$$Q_2 = Q_1 \sqrt{\frac{\Delta P_2}{\Delta P_1}}$$

Series 900 (70, 100, 150, 200 lph)

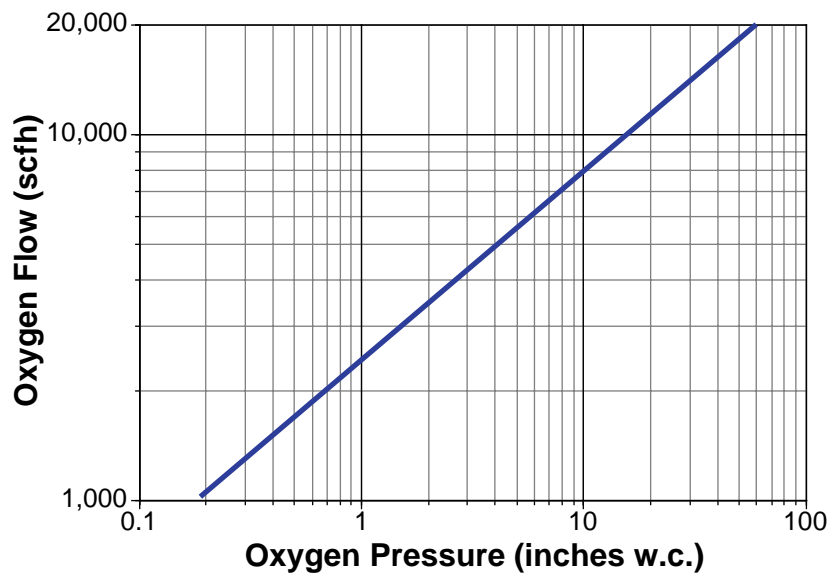

Capacity / Selection Data

Oil OXY-THERM® Burners Combustion Oxygen Pressure Curves

Series 900 (300, 400 lph)

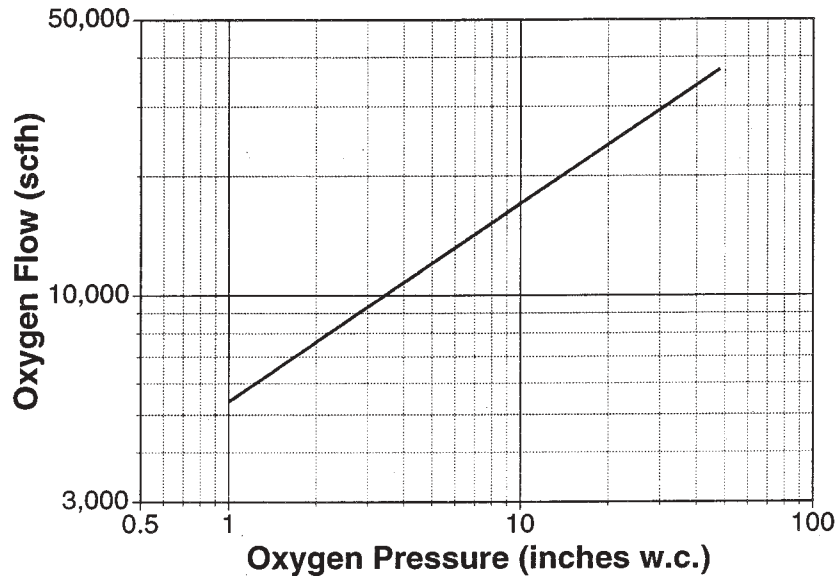

$$\Delta P_2 = \Delta P_1 \left(\frac{Q_2}{Q_1} \right)^2$$

$$Q_2 = Q_1 \sqrt{\frac{\Delta P_2}{\Delta P_1}}$$

Capacity / Selection Data

Oil OXY-THERM® Burners Atomizing Oxygen/Air Flow vs. Pressure

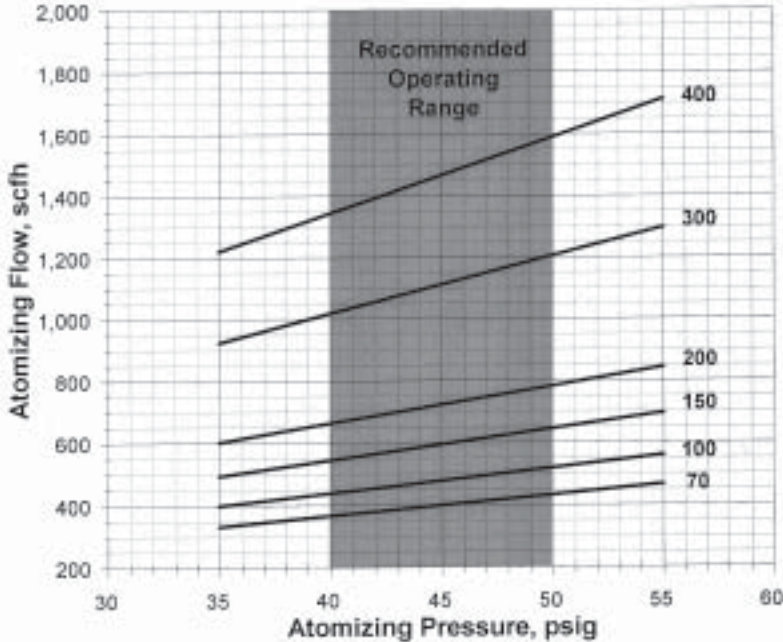

Each line represents a particular oil nozzle nominal rating, e.g., "400" represents the 400 liter per hour oil nozzle.

NOTES:

- If oxygen is used for atomizing, its volume should be factored in when establishing the excess oxygen requirements for each application. If air is used for atomizing, the volume of oxygen contained in the air is so small that it represents an insignificant amount of the oxygen required for combustion. Therefore, it should not be factored into the operating fuel/oxygen ratios.
- FOR ATOMIZING: Due to the design of the atomizer, variations in oil viscosity can affect flow rates at given pressures. Actual numbers may vary slightly.
- FOR OIL: Variations in actual oil viscosity and specific gravity will cause pressures and flows to be slightly different than shown.

Oil OXY-THERM® Burners Fuel Oil Flow vs. Pressure

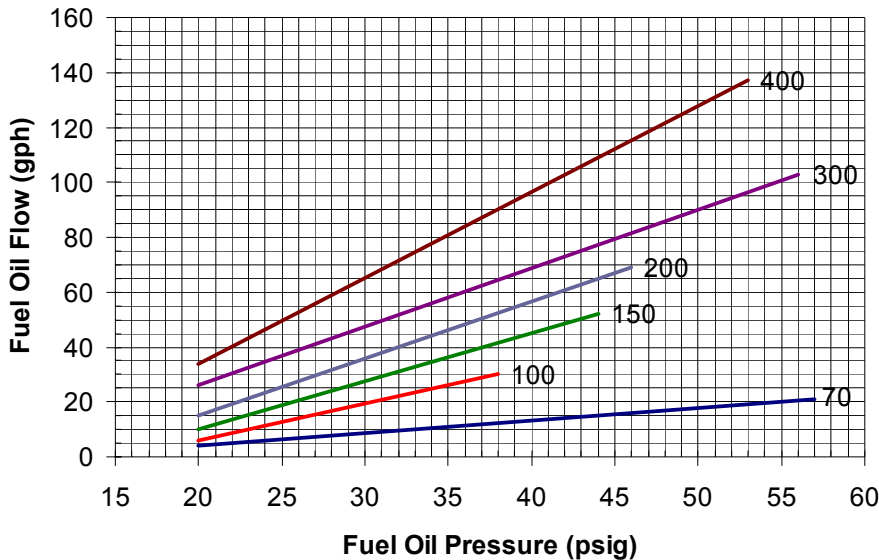

Dimensions *(in inches)*

Gas OXY-THERM® Burners

Series 600

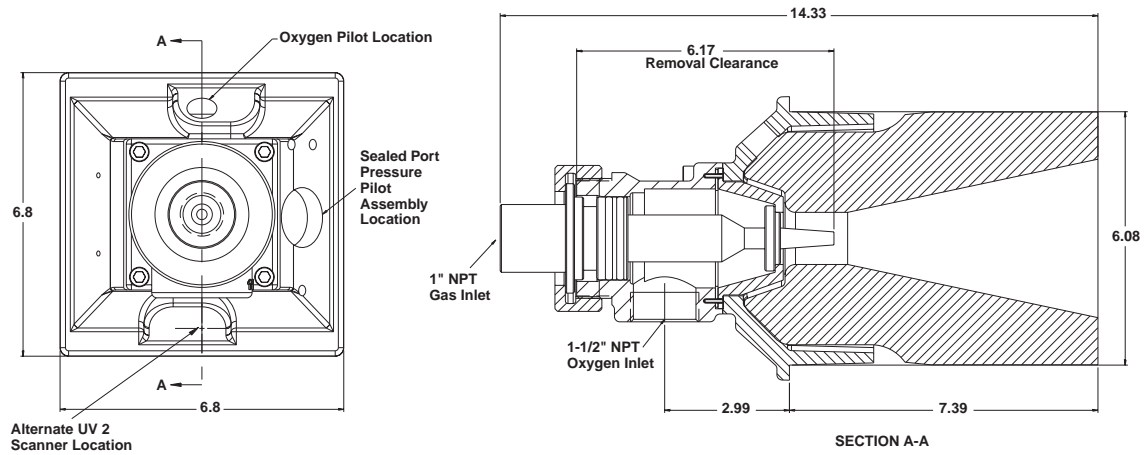

Series 900

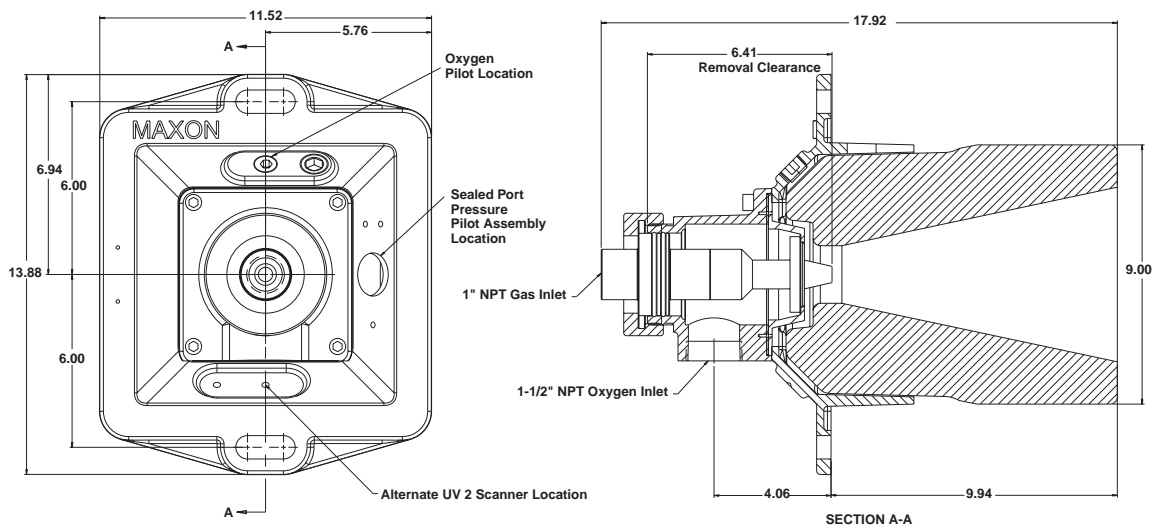

Dimensions (in inches)

Oil OXY-THERM® Burners

Series 600

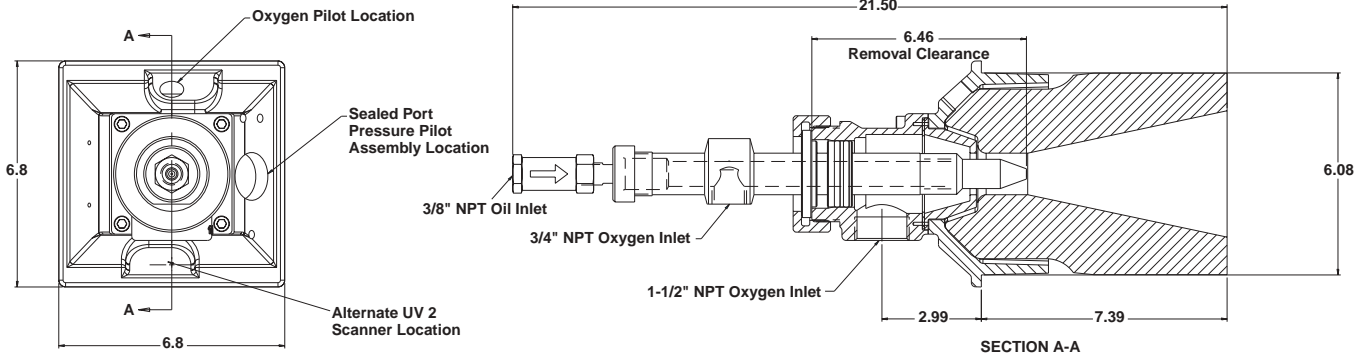

Series 900

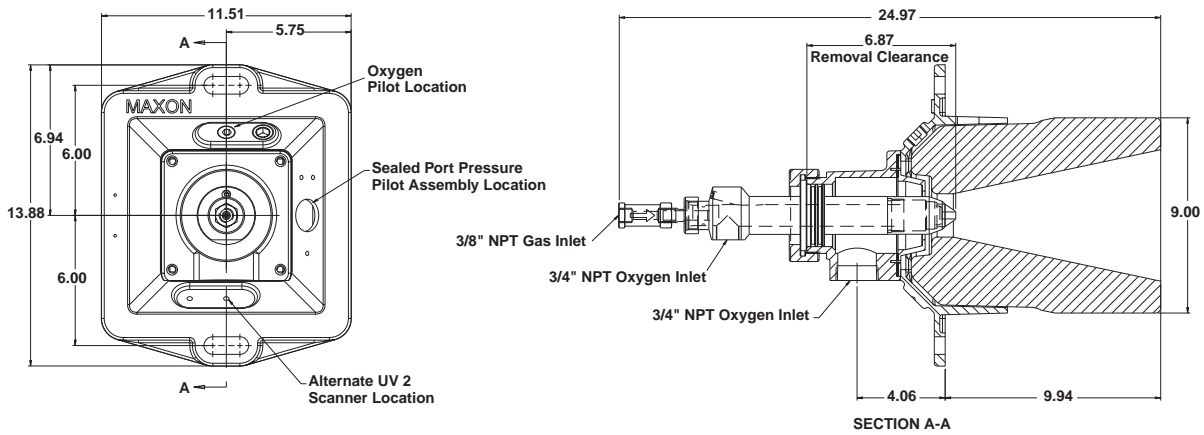

Dimensions *(in inches)*

Optional Pilot Arrangements

Oxygen Pilot

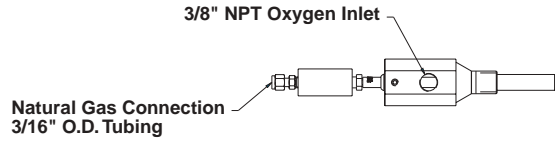

Sealed Port Pressure Pilot Assembly (Air Pilot)

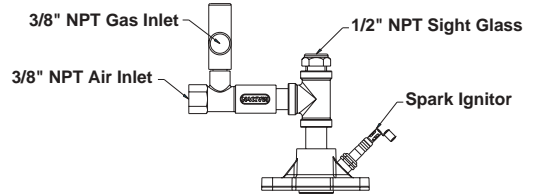

Oxy-pilot Specifications

Fuel	Flow	Pressure	Capacity
Natural Gas	25 CFH	2.25" wc	25,000 Btu/hr
Propane	10 CFH	0.83" wc	
Oxygen	53 CFH	0.5" wc	

Natural Gas Pressure	Combustion Air Pressure	Capacity
4 - 7" wc	8 - 16 osi	40,000 Btu/hr

Optional Pilot Locations (Air or Oxygen)

Series 600

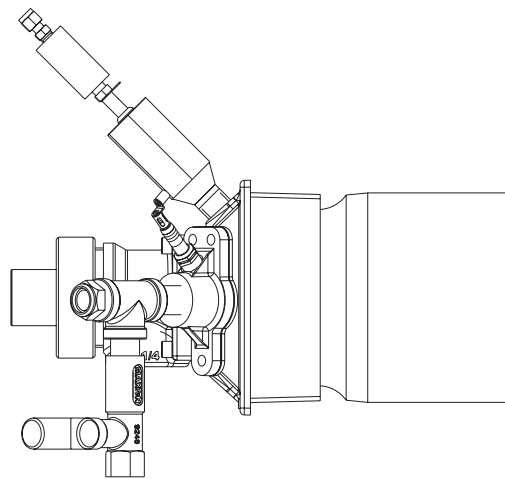
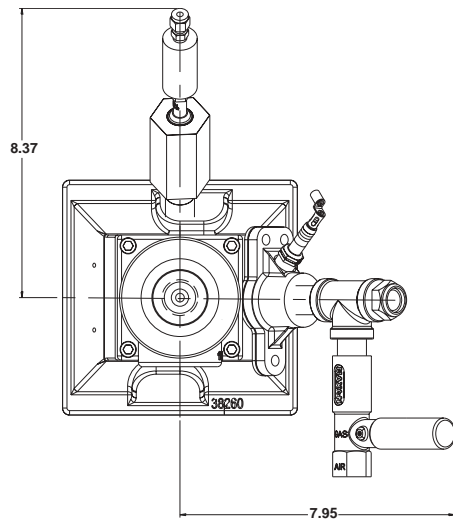

Series 900

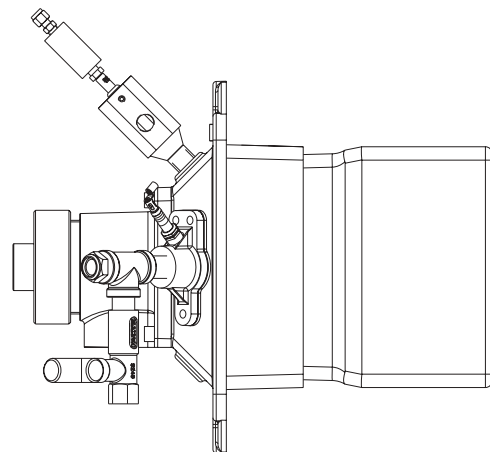
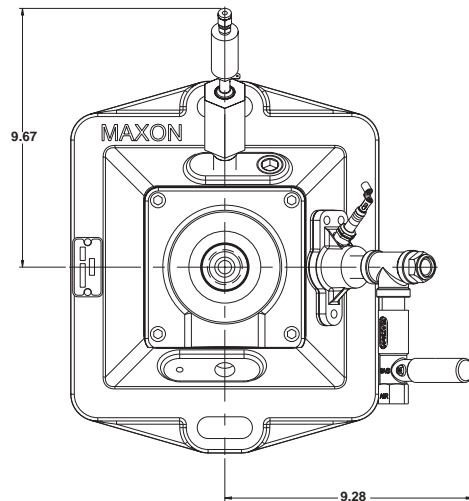

Component Identification

Gas OXY-THERM® Burners

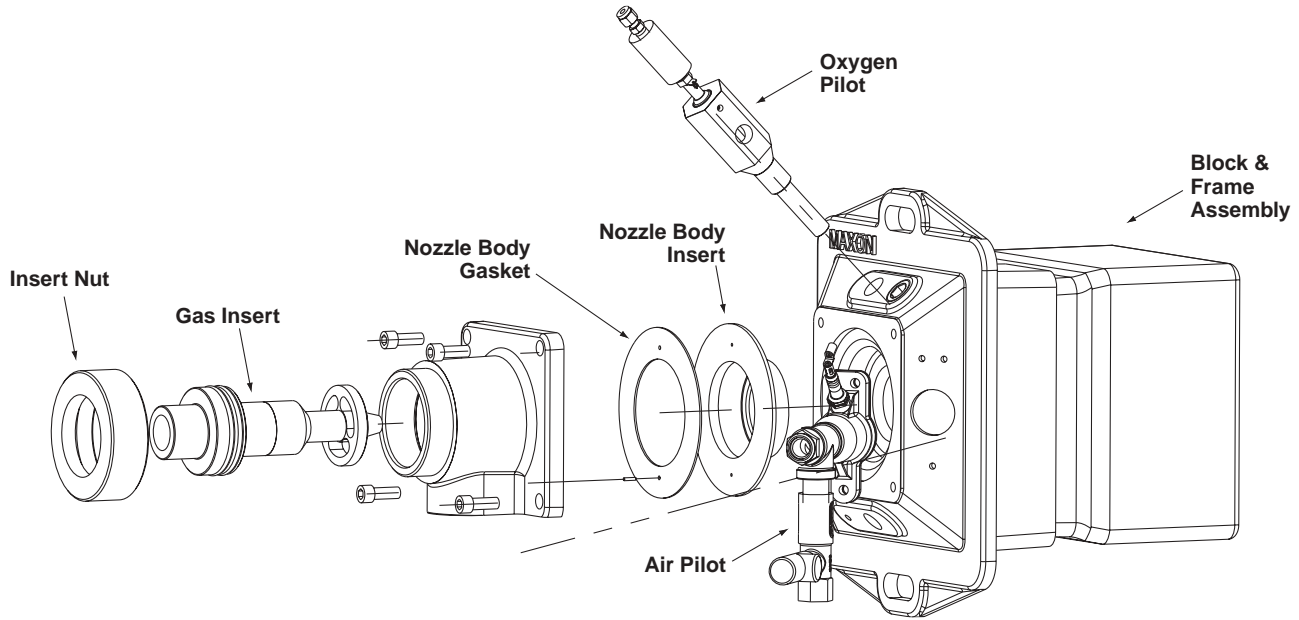

Oil OXY-THERM® Burners

